

FaceFix installation to a window frame / wall [F1]

- Do not damage the product when using a sharp knife to open the packaging!
- Fitting screws: Use a size-2 screwdriver (POZIDRIVE) or use an electric screwdriver at it's lowest torque.
- Rail removal: Use a flat screwdriver of max. 6 mm wide.
- Only use the original screws enclosed, to prevent malfunctioning from using too thick screw heads!

**Model
PB10
PB15**

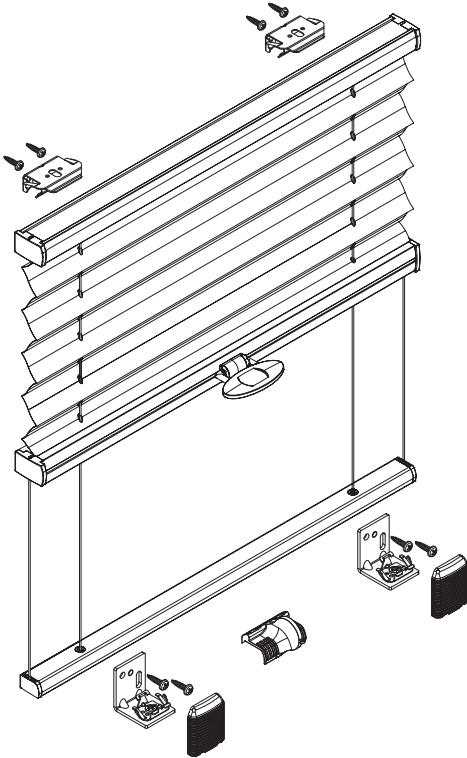

Product width	Number of parts						
0 - 80 cm							
81 - 115 cm	3	3	3	3	1	12	3
116 - 150 cm	4	4	4	4	1	16	4
	5	5	5	5	1	20	5

