

FaceFix installation to a window frame / wall [F1]

- Do not damage the product when using a sharp knife to open the packaging!
- Fitting screws: Use a size-2 screwdriver (POZIDRIVE) or use an electric screwdriver at it's lowest torque.
- Rail removal: Use a flat screwdriver of max. 6 mm wide.
- Only use the original screws enclosed, to prevent malfunctioning from using too thick screw heads!

**Model
BB20T**

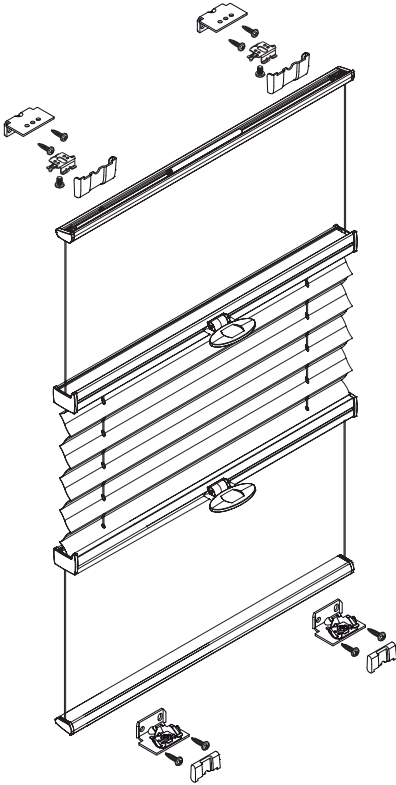

Product width	Number of parts					
0 - 80 cm						
	4	4	4	4	8	4
81 - 150 cm						
	6	6	6	6	12	6

